

TECHNICAL INSTRUCTIONS

Bio Turbo 6000 User Guide

AIRBORNE BACTERIA & ETHYLENE REMOVAL

Specification Sheet2
Installation Guide.....3
Layout Diagram.....5
Maintenance Guide6
Wiring Diagram.....7
Pull Sheet8



Bio Turbo 6000

Specification Sheet

Features

- LED's for quick diagnostics
- Remote On and Off control
- Easy service
- Easy changing of ozone plates and filters
- Four models for proper coverage
- Aluminum and Stainless Steel generation chamber
- Easy to install and operate
- Low maintenance

Model	BIO TURBO 6000
Maximum volume up to	200000 ft ³ (6000 m ³) per 24 hours
Airflow	150 CFM (4 CMM)
Location Requirements	
Electrical Source	100-240 VAC
Circuit breaker	15 A
Maintenance	
Air Filter	Change every 6 months
Ozone Plate(s)	Change every 12 months
Number of Ozone Plates	4
Specifications	
Dimensions:	
Generation Chamber	10 x 12 x 10 inches (25 x 30 x 25 cm)
Catalytic Converter/ Controller	12 x 19 x 16 inches (30 x 48 x 40 cm)
Reaction Chamber	4 x 8 x 2 feet (122 x 244 x 61 cm)
Weight	160 lb (60 kg)
Construction	
Materials:	
Generation Chamber	Aluminum
Catalytic Converter/ Controller	Aluminum
Perforated Generator Plate	Stainless Steel
Controls	
	Remote Control
	Power Switch

Bio Turbo 6000

Installation Guide

DESCRIPTION

The Bio Turbo 6000 is referred to, as the BT 6000. The 6000 indicates the amount of Cubic Meters the unit can properly control within a 24 hour period. The BT 6000 was designed to remove ethylene from cold rooms and storage areas where fruits and vegetables are stored in order to extend their storage life.

TECHNOLOGY OVERVIEW

STAGE 1: AIR FILTER

The air filter removes dust and visual particles from the air.

STAGE 2: CELL DISRUPTER

An anti-microbial chemical is applied to the surface of a specifically designed substrate. This combination pierces and ruptures cell membranes of airborne pathogens as they pass by, stopping the normal life development of the cells. This stage can be especially effective at controlling spores.

STAGE 3: OZONE CHAMBER

This chamber uses the positive effects of ozone to eliminate ethylene gas while destroying up to 99.5% of the bacteria and pathogens that are being broken down during the previous stage. The ozone is safely contained within the chamber providing a safe work environment.

STAGE 4: BIO CLEAN MODULE

In this final stage, a catalyst is used to change the ozone into clean oxygen. The catalyst creates a reaction that breaks down the ozone molecule. From here the clean oxygen is released back into the environment.

SYSTEM PLACEMENT

The Bio Turbo is designed to be mounted on the ceiling. Ethylene rises, so the higher the units are mounted the better.

WARNING: position the Bio Turbo in a way to avoid direct air flow from the coolers or fans to the air intake on a Generating Chamber.

A receptacle will be necessary to connect to either 110 V AC or 230 V AC power.

NOTE: due to the dimension of the Bio Turbo system, we recommend to have at least two installers.



Picture 1

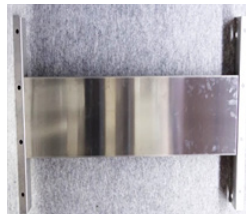

Picture 2

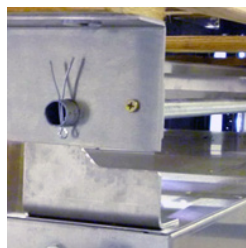

Picture 3

STEP 1: The large metal Reaction Chamber should be mounted first. The Chamber is 48" (122 cm) long and 29.5" (75 cm) wide.

Start with securing the mounting hooks with bolts to the Reaction Chamber (see picture 1).

Two wider hooks should be positioned in the front part of the reaction chamber (closer to Ozone Generation Box and Control Box), two narrower — on the back. Make sure all hooks are pointed towards the Ozone Generation Box and Control Box (see picture 3, 4).

You will find 2 L-brackets with mounting holes for attaching to the ceiling (narrowed side of the L-bracket) and holes for long metal holding pipes (wider side of the L-bracket). L-brackets should be assembled together with a cross member panel as it is shown on a picture 2.

When assembling pair of L-brackets, make sure that the small holes on L-brackets, right next to the holes for pipes, are pointed toward the Ozone Generation Box and Control Box — those holes are made for the safety screws which go into the wide front hooks (see picture 3).

Bio Turbo 6000

Installation Guide

The distance between two long metal pipes on which the reaction chamber has to be hanged on, should be 85.5" or 2171.7mm or 7.125' (see picture 4).

Mark on a ceiling the position of second pipe and attach the second (rear) pair of L-brackets accordingly, to match the pipe holes as marked.

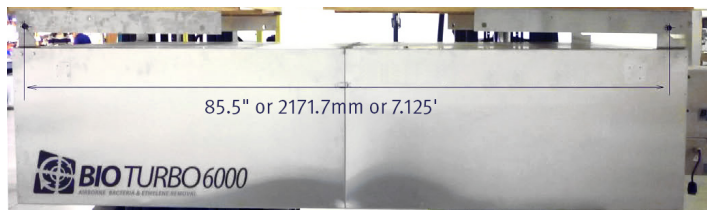

Picture 4

After attaching all L-brackets, inserting pipes and locking them with pins – hang the Reaction Chamber as shown on picture 4.



Picture 5

STEP 2: The catalyst is in a separate chamber of the Catalytic Converter. Simply open the top section of the Catalytic Converter and pour the catalyst into this section. The required amount is supplied in the BT 6000 Starter-kit (see picture 5).

STEP 3: The Generation Chamber and the Catalytic Converter should be mounted by inserting them into the Reaction Chamber (tilt the smaller boxes at an angle allowing them to be placed into the Reaction Chamber slot) (see picture 6).

Then screw the Generation Chamber and Catalytic Converter to the Reaction Chamber (see picture 6).

STEP 4: Plug the remote into the controller and route the remote box to the desired location.

STEP 5: Plug power cord from Generation Chamber into the female socket on the Controller Box.



Picture 6

STEP 6: Plug the detachable power cord into the male socket on the Controller Box and the power supply receptacle. Either 230 V AC or 110 V AC. The system's operating voltage is shown on the serial number label on the side of the catalyst converter unit.

STEP 7: There should be two LED's "glowing green" on the Controller.

STEP 8: Turn "ON" the power switch on the remote control. The other two LED's should "glow green" and then the fan should start. At this point, the system will be fully operational.

STEP 9: The LED on the side on the Generation Chamber should be "glowing green".

The Generation Chamber should also emit a low hum indicating the Generator plates are producing Ozone.

COUNTDOWN SERVICE TIMER

System is equipped with the Service Timer which is counting down days to the next maintenance when system is operating. Timer is set to 360 days and when it gets down below 10 days it starts beeping and Service Red LED light on the controller box and the strobe light on the remote control will flash, signaling maintenance is due. Service Timer has to be reset back to 360 days after maintenance is completed (see maintenance guide page for further instruction).

NOTE: please apply the BT Facility Entrance Label #25070, supplied in a pack with system, near the facility entrance (see picture 7).

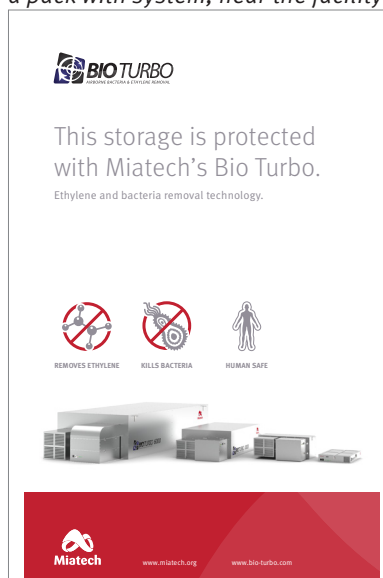

Picture 7

Bio Turbo 6000

Layout Diagram

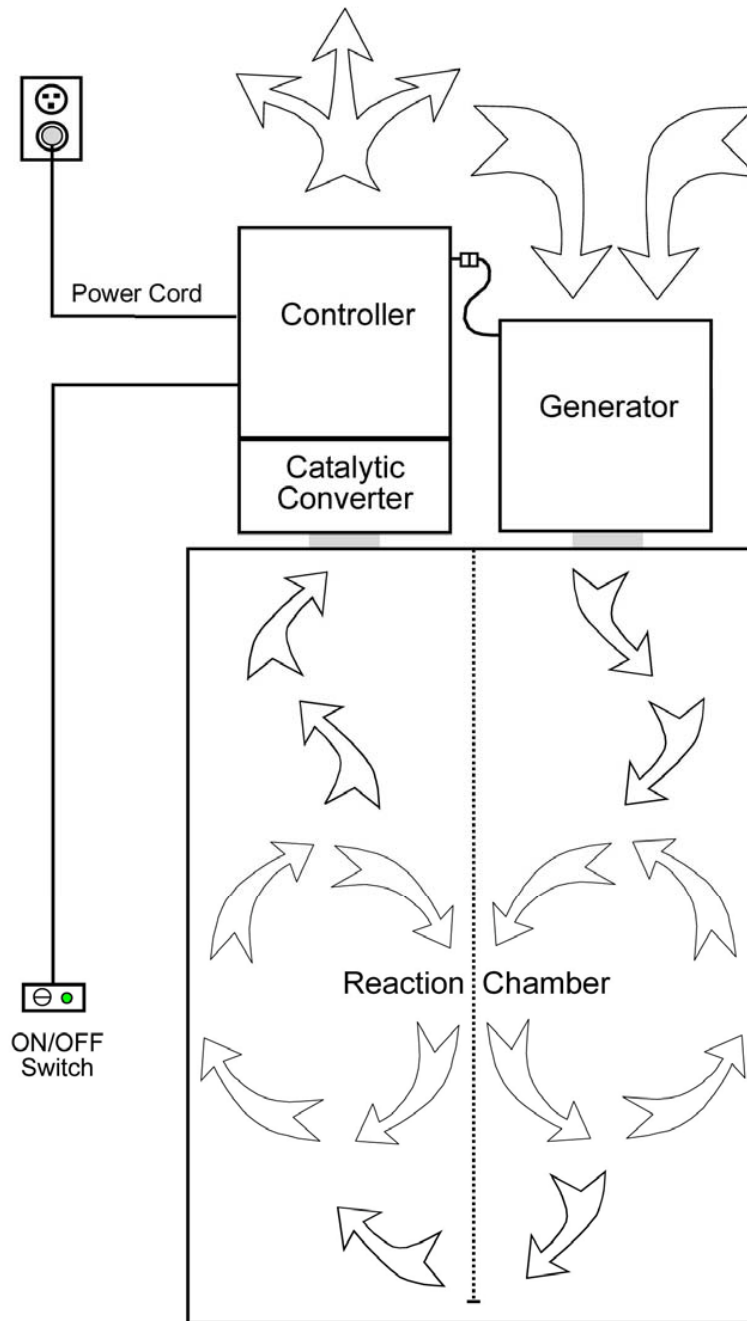

Bio Turbo 6000

Maintenance Guide

CAUTION:

ALWAYS UNPLUG POWER BEFORE SERVICE!

Maintenance Requirements

Annual service requires the replacement of Ozone Generation Plates.

Semi-annual service requires the replacement of Air Filter (more often if environment is very dusty).

To replace the Air filter and the Ozone Generator Plates:

- Unlatch the bottom cover on the Generation Chamber and remove the Air filter (#12).

CAUTION: Slowly and carefully open the cover to ensure the filter does not fall down. The door helps to secure it in place.

- To replace the Generator Plates (#16) release plastic holders from the cassette, remove Generator Plates and replace with new one. Fix plastic holders back on place to secure Generator Plates.

System is equipped with the Service Timer (#5) which is counting down days to the next maintenance when system is operating. Timer is set to 360 days and when it gets down below 10 days it starts beeping and Service Red LED light on the controller box will flash, signaling maintenance is due. Service Timer has to be reset back to 360 days after maintenance is completed.

To reset the Service Timer:

Carefully press and hold the button for about 10 sec. until numbers will start flashing. By releasing and pressing again the same button select 360 from the options. Wait until it is defined (numbers will stop flashing).

NOTE: a blunt object should be used to reset, so damage won't occur to the timer.

Diagnostic LED's Name	Description
“Power” (on the Remote Control)	Power to the Main Switch
“Breaker” (on the Controller Chamber)	Power to the Unit
“Power IN” (on the Controller Chamber)	Power to the Power Supply
“24 V” (on the Controller Chamber)	Power to the Fan
“To the Generation Chamber” (on the Controller Chamber)	Power to the Generation Chamber
“Service” (on the Controller Chamber)	When the service is needed or when protection triggered
Strobe Light (on the Remote Control)	When the service is needed or when protection has triggered

NOTE: If service Red LED comes ON along with strobe light, and timer is showing more than 10 – the ozone generation current protection might be triggered. This could happen due to the damage of ozone plates or power jump in power supply network. Unplug the system and check the ozone plates. If this happened because of power jump – restart the system by switching it OFF on a remote control and put back ON after 30 seconds.

NOTE: In case of frequent triggering of ozone generation current protection, locate the fuse board (#23290) inside the controller chamber and put the jumper on two pins (see picture 1).

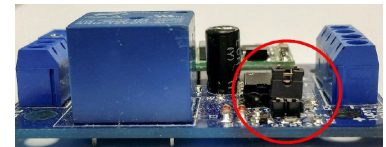

Picture 1

Controller chamber



Controller chamber

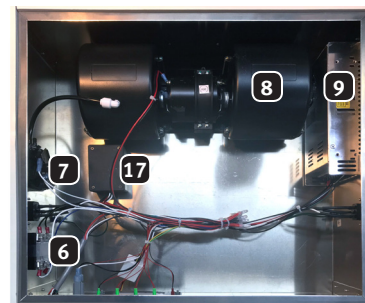

Power cord



Remote control



Generation chamber

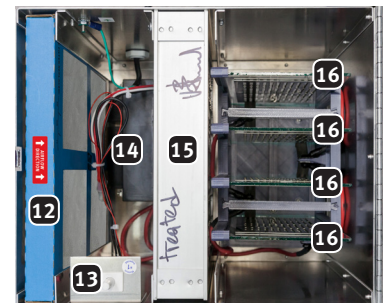

1. 15 Amp Breaker (#233007)
2. 24 V LED (#23140)
3. Service 24 V LED Red (#23292)
4. 3 LEDs 115 V (#23192), 230 V (#23193)
5. BT service timer (#23267)
6. Solid state relay (#23222)
7. Airflow Safety Switch(#14018)
8. Fan (#10031)
9. 24 V DC 14.5A Power supply (#23224)

10. Rocker switch (#23132)
11. Strobe light (#23076)
12. Air filter (#11139)
13. Door Switch (#23233)
14. Ozone transformer (#23231)
15. Cell disrupter (#11124)
16. Generator plates (#11127)
17. BT Fuse Board (#23290)
18. Timer Reset Hole
19. Power Cord US plug (#23317) / EU plug(#23318)

Bio Turbo 6000

Wiring Diagram

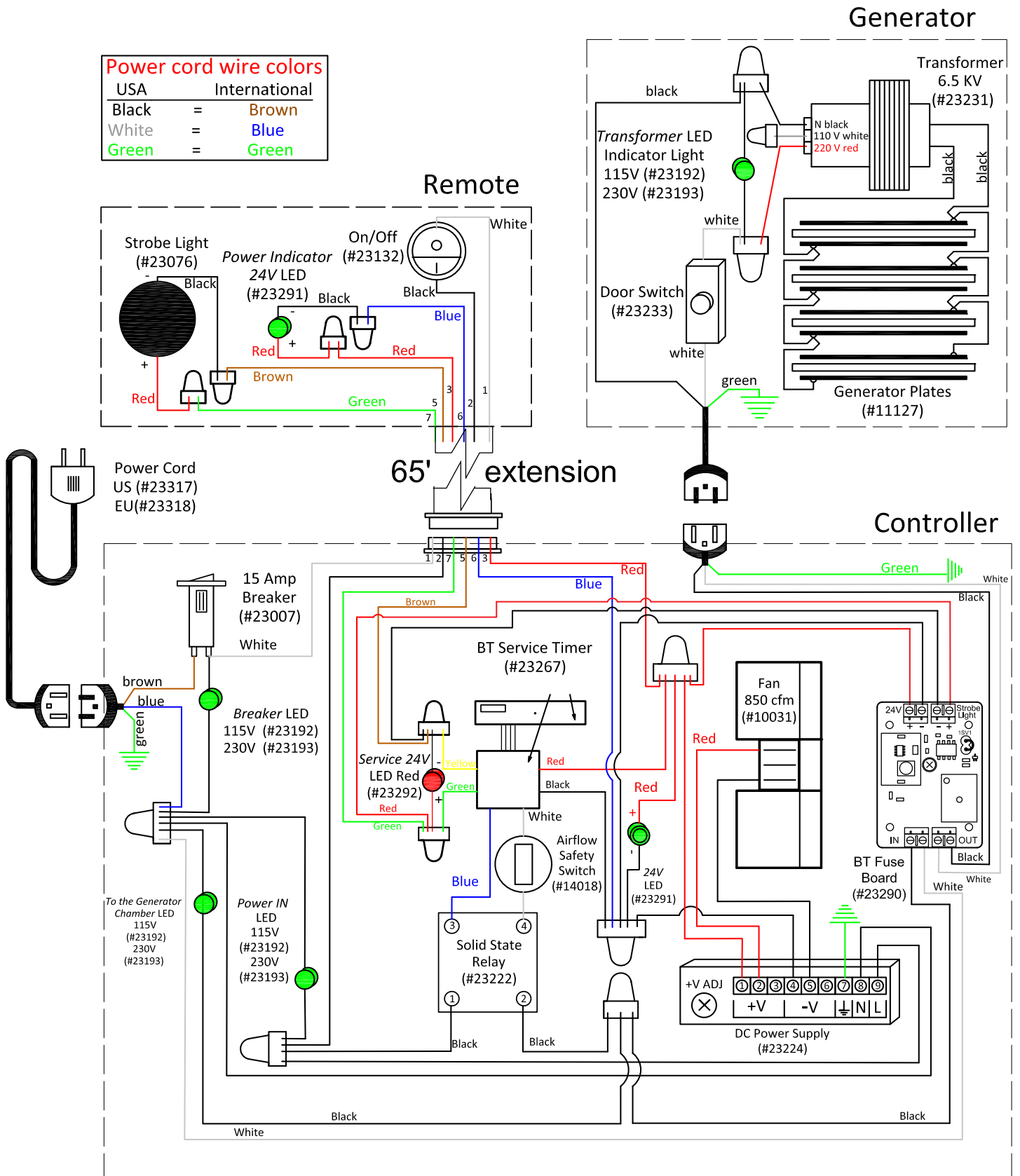

Bio Turbo 6000

Pull Sheet Pack

PART NO.	PART NAME	AMOUNT	INSP.
11108	Catalyst Bio Turbo	22 lb	
16096	BT 1K & 6K Hanging Bracket - Right Angle 3 1/4" x 1 3/4" x 29"	2	
16098	BT 6K Hanging Bracket - Panel 12" x 47" x 2"	2	
16100	BT 1K & 6K Hanging Bracket - Standard Hook Kit (smaller left and right, larger left and right, total 4 pcs.)	1 set	
16102	Mounting Angle Left Side	2	
16106	Conduit/Tube 50"	2	
24001	#8 x 3/4" Self-tapping Tek Screw (Phillips)	25	
24070	1/4-20 x 3/4 Hex Head Cap Screw	11	
24078	Cable Tie 6" Black	25	
24083	10-32 x 3/8 Phil. Screw	11	
24101	1/4" x 1 Fender Washer	8	
24102	1/4" x 8" Threaded Rod	8	
24103	1/4 Lock Nut	10	
24104	1/4" Toggle Fastener	8	
24113	Cotter Pin 1/8" x 1 1/4" Zinc	7	
N/A	Remote with 65' Cord	1	
26081	Foam Tape	17'	
25070	BT Facility Entrance Label *See order for language	1	
	Power Cable 6' 18g with female end *See order for the plug	1	

DATE _____

PULLER _____

CHECKER _____



Miatech Inc.
9480 SE Lawnfield Road
Clackamas, OR 97015
www.miatech.org

For further technical support in North America call 1-800-933-6478
If outside North America call to the USA at 1-503-659-5680